

MPB Series

15,000 PSI, Ultra High Flow Ball Valves



Large Bore, High Flow

Parker's High Flow Ball Valve provides high flow rates without sacrificing working pressures. The 2507 Super Duplex body provides the strength necessary for medium pressure applications. End connections are Parker's MPI™ (Medium Pressure Inverted) fittings which allows for quick installation and dependable service. Parker's Parofluor™ V8588-90* perfluorinated elastomer seals resist the aggressive chemical media common to the oil and gas industries.

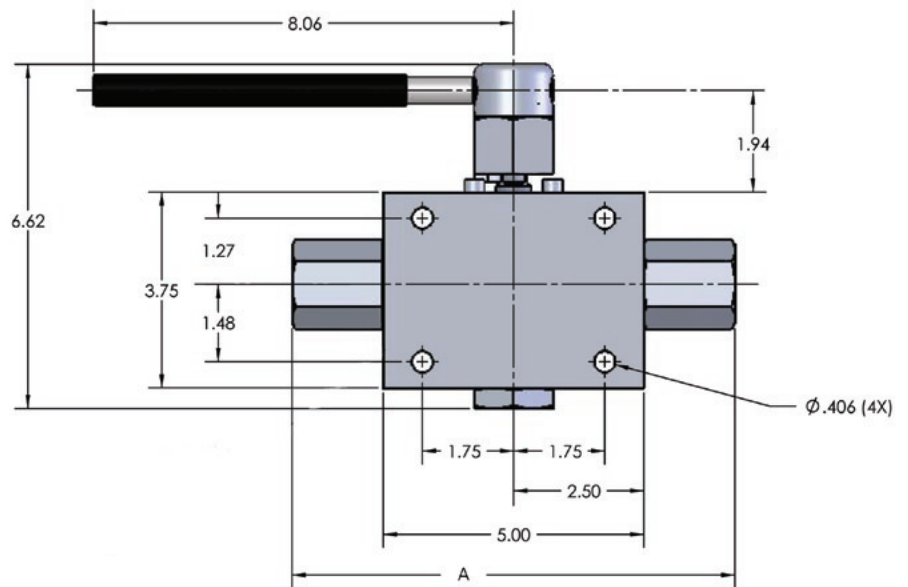

Contact Information:

Parker Hannifin Corporation
Instrumentation Products Division
2651 Alabama Highway 21 North
Jacksonville, AL 36265-681 USA

phone 256 435 2130
fax 256 435 7718

www.parker.com/ipdus

Ideal for Severe Duty Applications

- Bi-directional trunnion style closure
- Blow out proof stem
- Optional packing, seal, spring, and seat materials available**
- 4 hole rack mount bolt pattern
- For applications up to 15,000 PSI
- .47" Orifice for high flow

* See Parker O-Ring Division Technical Bulletin No. 5722B1-USA for complete details and test data.

** Consult factory for available options.



ENGINEERING YOUR SUCCESS.

Technical Information

Specifications, Materials and Dimensions

Specifications

Working Pressure	Up to 15,000 PSI
Orifice Sizes	.47"
Standard Connections	Parker MPI™ Fittings
Typical Application	Chemical Injection Skids
Typical Materials	<ul style="list-style-type: none"> • 316 cold-worked stainless steel trim • 2507 Super Duplex body • Fiber-reinforced PEEK seats • Parker Parofluor™ perfluorinated elastomer seals

Materials

Item #	Description	Material
1	Body	Duplex 2507
2	Stem	Inconel 625
3	Bearing Washer	Nitronic 60
4	UNIF-112 O-Ring	V8588-90
5	UNIF-112 Backup Ring	PEEK
6	Top Bearing	Nitronic 60
7	Trunnion	316L SS CW
8	Bottom Blank	316L SS CW
9	Bottom Bearing	Nitronic 60
10	UNIF-215 O-Ring	V8588-90
11	Seat Retainer	17-4 PH H900
12	Seat Seal	30% GF PEEK
13	Spring Washer	Inconel 718
14	Follower	316L SS CW
15	UNIF-113 Backup Ring	PEEK
16	UNIF-113 O-Ring	V8588-90
17	End Adapter / # 12MPI	316L SS CW
18	Socket Head Cap Screw	316 SS
19	Hub	316L SS CW
20	Knurled Set Screw	18-8 SS
21	Thread Disc	Nylatron
22	Handle	316L SS CW
23	Handle Grip	PVC
24	Socket Set Screw	18-8 SS

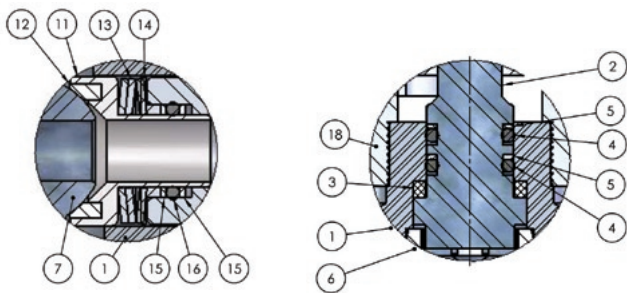
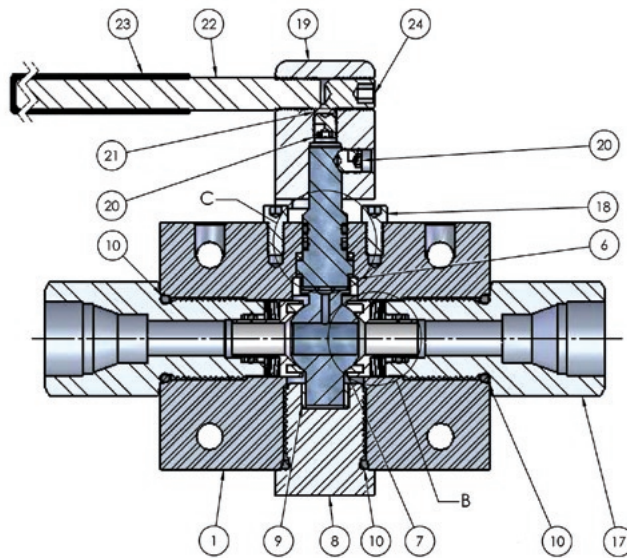

Dual Handle Option*: Items 1-21 same as above

Item #	Description	Material
22	Handle	316L SS CW
23	Handle Grip	PVC

* To order the Dual Handle option, add "-DH" to the end of the part number.

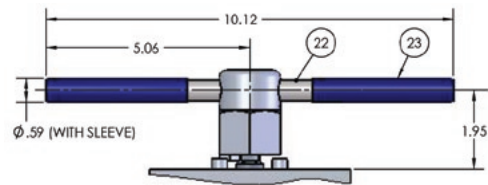

Dimensions

Size	Parker Part Number	PSI	Connection	Orifice	Inches		
					Minimum Orifice	C _v	A
Ultra High Flow (UH)							
3/4"	12MP7-MPBLPKPUH-KZ*-SSP	15,000	3/4" MPI	0.470	0.470	7.6	8.51
1"	16MP7-MPBLPKPUH-KZ*-SSP	12,500	1" MPI	0.470	0.470	7.6	10.13

* Perfluorinated elastomer is standard. Please consult the factory for optional materials.

